

# INSTRUCTIONS FOR VARILIGHT V-DIM SAFETY DIMMER SWITCHES

Thank you for choosing a VARILIGHT dimmerswitch. Use only on an electricity supply of 230 volts AC.

**IMPORTANT:** Read ALL sections below before installing this dimmerswitch.

V-Dim safety dimmers are protected against overload. Please refer to "Overload Protection".

This product complies with **European Safety Regulations** (IEC 669-2-1 or BSEN 60669-2-1).

**Doyle & Tratt Products Ltd**, Carylls Lea, Faygate, Horsham, W. Sussex, RH12 4SJ, UK. +44(01293) 223333

**Varilight Europe Kft**, 2600 Vác, Althann Mihály Frigyes utca 2, Hungary.

## LOADING

**Always observe the recommended maximum load as specified on the product label.**

**\*WARNING:** At maximum loading some light bulbs may overload the dimmer because they present a higher load than their rating. If in doubt, reduce the load.

**\*\*HALOGEN LIGHTS:** We recommend using 1-Way Rotary V-Dim series dimmer (1-way circuits) OR Intelligent Soft Start V-Plus series dimmers (1- or 2-way circuits) for this type of lamp.

### THIS SWITCH IS SUITABLE FOR

- ✓ Mains incandescent (GLS bulbs and spotlights)
- ✓ Mains halogen lighting
- ✓ Good quality dimmable electronic low voltage transformers [see "Transformers"]

### THIS SWITCH IS NOT SUITABLE FOR

- ✗ LED lighting [Choose V-Pro or V-Corn]
- ✗ Wire-wound or Toroidal Transformers
- ✗ Non-dimmable fluorescent bulbs and tubes
- ✗ Electric motors

### TRANSFORMERS

This dimmer can control dimmable electronic transformers. To calculate the load, add up the wattages of all connected transformers (e.g. 7 × 50W = 350W, so use a 400W dimmer). Always use high-quality dimmable transformers, such as those made by VARILIGHT. If using transformers from other brands, we recommend a maximum of 5 per dimmer circuit, as noise levels can vary depending on the type and number used.

### OVERLOADING AND UNDERLOADING

Dimmers must not be overloaded or underloaded.

To calculate the load:

- Add up the wattage of all the bulbs controlled by the dimmer.
- Check the label on the back of your dimmer for max and min load ratings.
- Adjust according to the load type if needed (see transformer guidance above).

If the lights flicker, the dimmer is likely underloaded. For best energy savings and performance, V-Dim dimmers should have a minimum load of 100W. Dimmer switches not only save energy but also extend bulb life.

### OVERLOAD PROTECTION

The dimmer has built-in overload protection. If overloaded, it will automatically switch off and pulse the lights on and off until the overload is removed and it cools down. To avoid this, make sure the dimmer is correctly loaded. Refer to the loading guidance above before installation.

## GUARANTEE TERMS

Varilight undertakes to repair or replace, at its discretion, goods which have become defective, solely as a result of faulty materials and workmanship, provided that:-

a) The unit has been correctly fitted according to the instructions and has not been used with an incompatible load, fluorescent tubes, or overloaded beyond its rating, and has only been used on a 200-250V a.c. power supply.

b) The dimmer module has not been tampered with or taken apart. However, for your convenience, it is perfectly in order to remove a faulty dimmer module from multi-gang dimmers by pulling off the knob and unscrewing the nut under the knob. You will then still have the remaining modules working whilst we service your faulty module.

c) The unit is securely packed and safely returned to either address listed in the overview section above, together with a letter stating the guarantee registration number below, the date and place of purchase, your contact details and return address, the type and wattage of the lighting or other load being controlled and the details of the fault. This guarantee states Varilight's entire liability, which does not extend to cover consequential loss or damage or installation costs arising from a defective product. The guarantee does not apply to problems arising from any incompatibility between your lamps and the dimmer switch. This guarantee does not in any way affect the statutory rights of the purchaser and is offered so that you may have the benefit of our technical facilities. In many cases products don't need replacing, so for further information and help with troubleshooting, see our FAQ page at [www.varilight.co.uk/faqs](http://www.varilight.co.uk/faqs), or contact our Customer Services by calling +44(01293) 223333 or create a support ticket at [www.varilight.co.uk/help](http://www.varilight.co.uk/help).



www.varilight.co.uk	<b>T</b>
Please <b>record the batch number</b> printed on the side of the plastic moulding on the rear of the product. This will assist us in providing any technical support you may require.	
<b>GUARANTEE REG NO: T009</b>	
BATCH NO:	
<b>INSTALLERS</b> – Please leave these instructions with your customer for future reference.	

## FITTING YOUR DIMMER SWITCH

There are two main types of lighting circuits—**1-way** and **2-way**—and dimmer switches can also come in **multi-gang** versions (2, 3, or 4 control knobs). Follow the instructions below carefully to install your dimmer switch correctly. If in doubt, consult a qualified electrician.

**WARNING:** Do not apply products with metal faceplates directly to freshly plastered or damp surfaces as product may tarnish. If in doubt, use polythene as a temporary gasket to protect the product. Do not use masking tape on metal faceplates.

### Step 1: Switch Off the Power

Turn off the power at the mains. Remove your existing switch and take note of how the wires are connected. Where two or more wires were connected together in the old switch, keep them together in the new dimmer.

### Step 2: Check the Wall Box

Ensure the wall box is free of plaster lumps and protruding screw heads. Recommended back box depths are available at [www.varilight.co.uk](http://www.varilight.co.uk).

### Step 3: Identify Your Circuit Type and Wire the Dimmer

#### 1-Way Circuits

These control the light(s) from a single switch.

- Use a 1-way rotary dimmer or a push-on/push-off dimmer (suitable for 1- or 2-way circuits).
- Push-on/push-off models let you turn the lights on/off with a push, keeping your selected brightness level.
- Connect the wires from your old switch to terminals "C" and "L1" (either way round).
- If using a push-on/push-off dimmer, ignore the spare "L2" terminal.

#### 2-Way Circuits

These allow control of the same light(s) from two locations (e.g. at both ends of a staircase).

- Only replace **one** switch with a dimmer to avoid flickering.
- Connect the wire from the "common" terminal of your old switch to "C" on the dimmer.
- The other two wires go into "L1" and "L2" (either way round).
- Note: On most dimmers, "C" is next to "L1" and "L2"; on many standard switches, "C" is at the opposite end.

#### Multi-Gang Dimmers (with 2, 3, or 4 knobs)

Each set of terminals on the back works as a separate dimmer.

- Wire each one as described above for 1-way or 2-way circuits.
- If needed, you can link one terminal from each module with a short wire to match the configuration of your old switch.

### Step 4: Earth the Dimmer (if needed)

If your dimmer has a metal faceplate, connect the earth wire to the earthing point on the plate.

### Step 5: Fit the Dimmer

Carefully screw the dimmer into the wall box without bending or cracking the faceplate. Ensure no wires are trapped behind the unit and no bare wire is exposed.

### Step 6: Power On and Test

Restore the mains power. Turn the dimmer on and adjust the knob to set the brightness.

A slight buzzing noise during operation is normal.

**Important:** Disconnect the dimmer before carrying out insulation resistance testing. Failure to do so may damage the dimmer and void the guarantee.

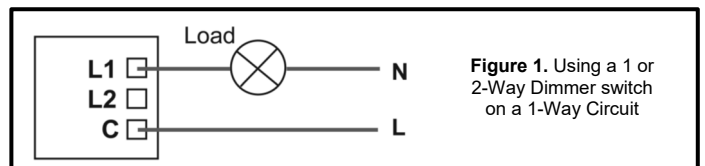

**Figure 1.** Using a 1 or 2-Way Dimmer switch on a 1-Way Circuit

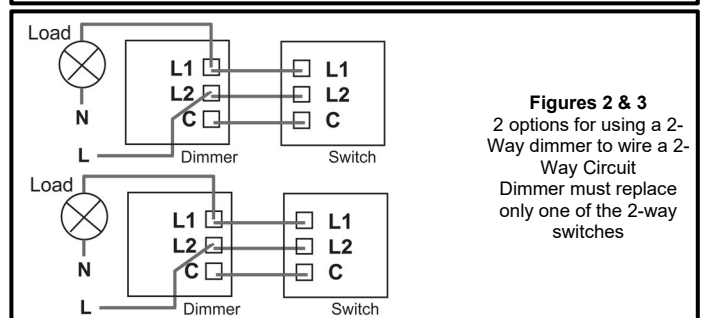

**Figures 2 & 3**  
2 options for using a 2-Way Dimmer switch on a 2-Way Circuit  
Dimmer must replace only one of the 2-way switches